



Technical Rider Rockj3 Quartet

1. Stage

min. 7 m x 5 m

2. Power

Power chords as mentioned in the stage plot 230V (Schuko!!), 16A

3. Monitoring

4 way - 4 wedges for each musician

4. PA

Depending on venue size, appropriate and high quality (min. 3 or 4 way system)
L-Acoustics, D&B, EV, etc. are preferred.

5. Lights/FX

Min. 24 KW, appropriate for the event

6. Parking

2 parking slots (Van) are needed from load-out until load-in

7. Stage Plot

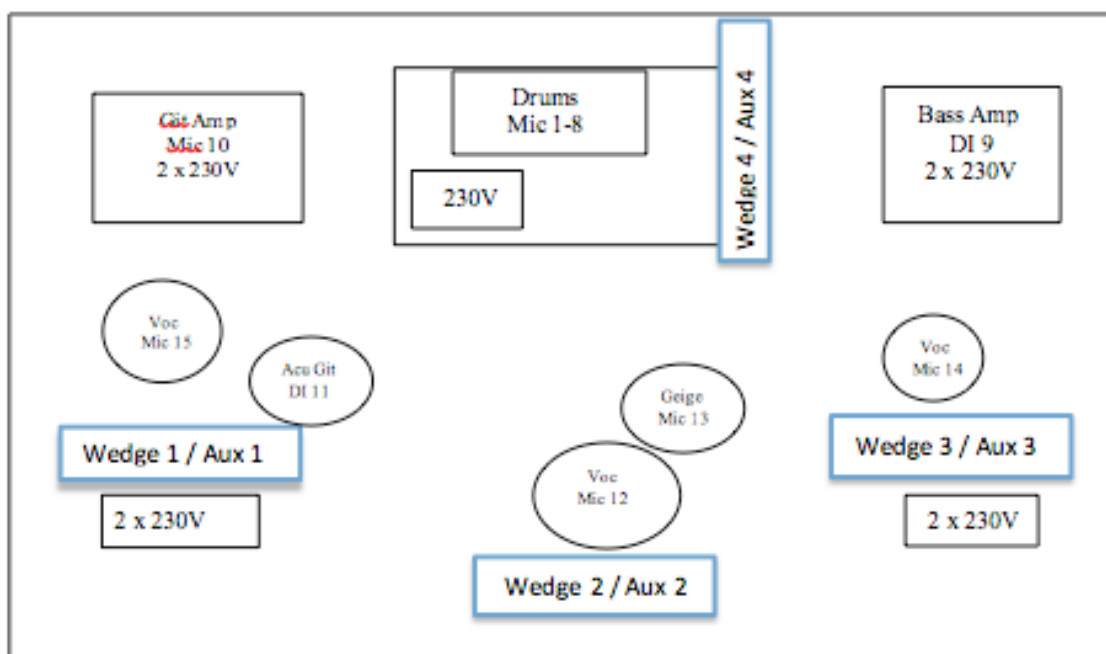



8. Channellist

Stagebox	FOH	Mic (or similar)
1	Kick	Audix D6
2	Snare top	Audix i-5
3	Snare bottom	E604
4	Hi Hat	AKG C480
5	Tom1	Audix D4
6	Tom2	Audix D2
7	OH L	AKG C480
8	OH R	AKG C480
9	Bass DI	XLR
10	Git Amp	SM 57
11	Acu Git	DI
12	Lead Voc	Beta 58
13	Geige	Condenser/Dynamic Clipmicro
14	Back Voc Bass	Beta 58
15	Back Voc Git	Beta 58

9. Local technician/stagehands:

From load-out until load-in there has to be one qualified local technician which is familiar with the whole equipment and able to mix a band. Additional 2 sober and strong stagehands which help loading.

When the band arrives the whole sound and light system has to be set up. After the backline is finished the microphone setup is done by the local technician.

Ansprechperson Band:

Sandra Eder

tel. +43 650 280 21 75

mail. booking@fancyartists.at